

Mill Start Panel

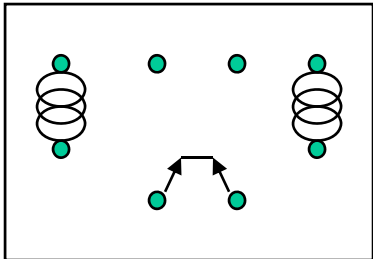

Contactors & Re-settable Thermal Cutouts

I/C Mains

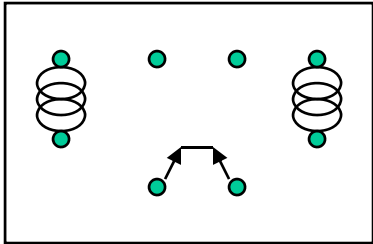
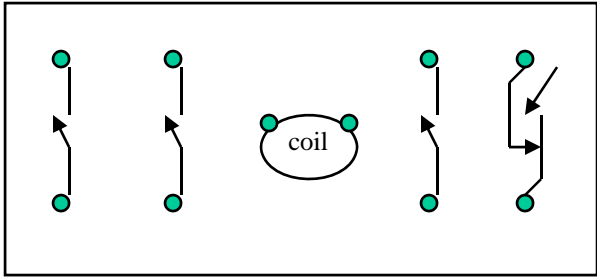
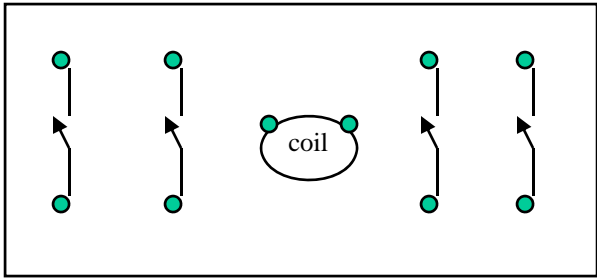
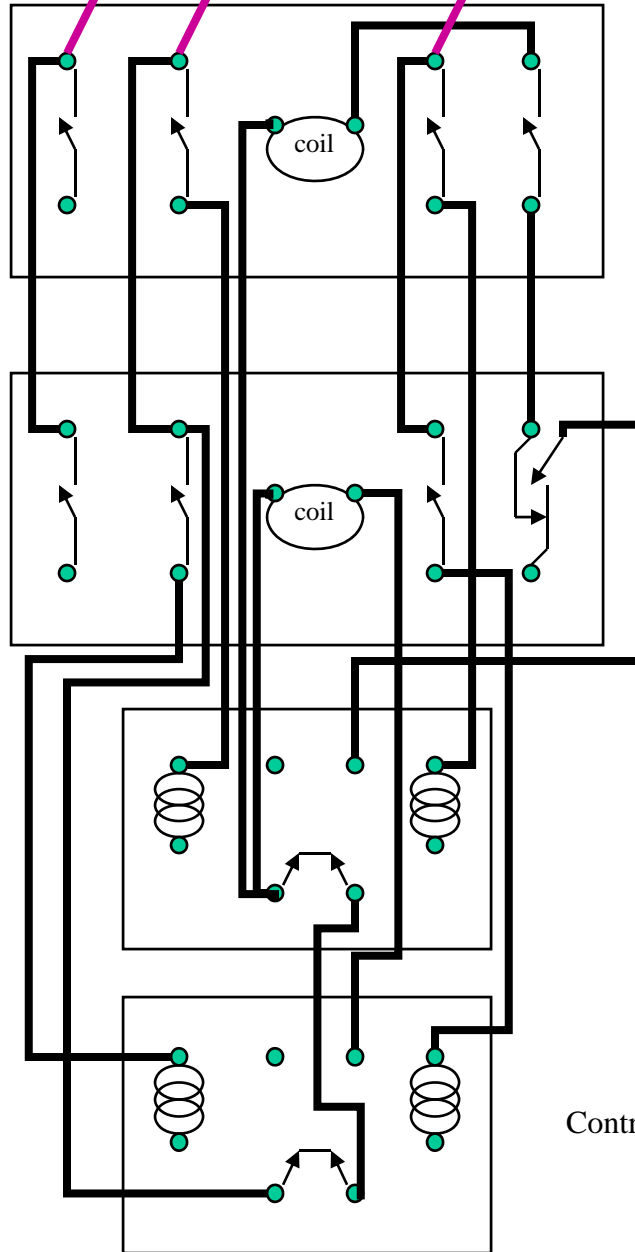

Control Box Internal Wiring & I/C 3 Phase

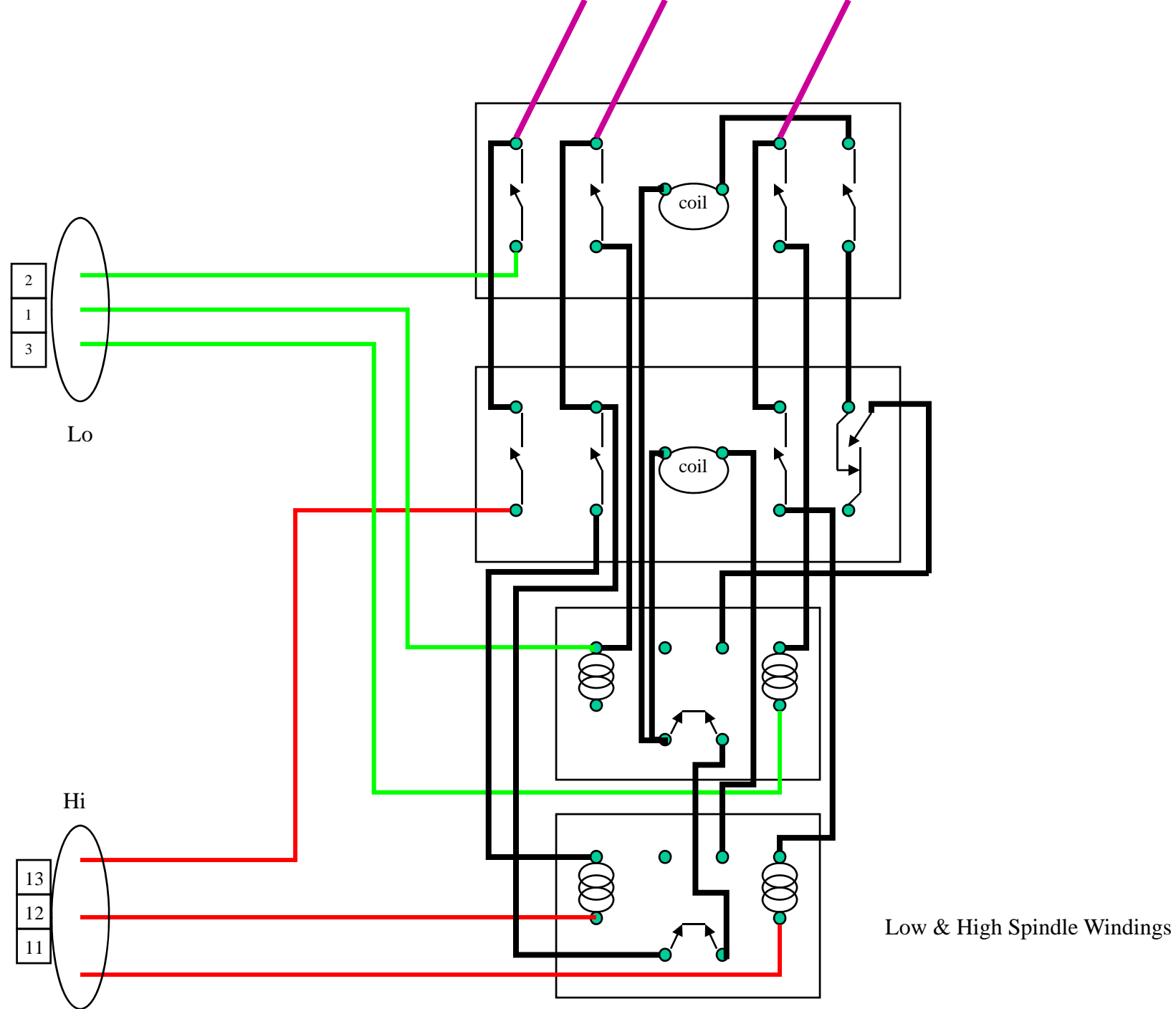

I/C Mains

- 2
- 1
- 3

Lo

Hi

- 13
- 12
- 11

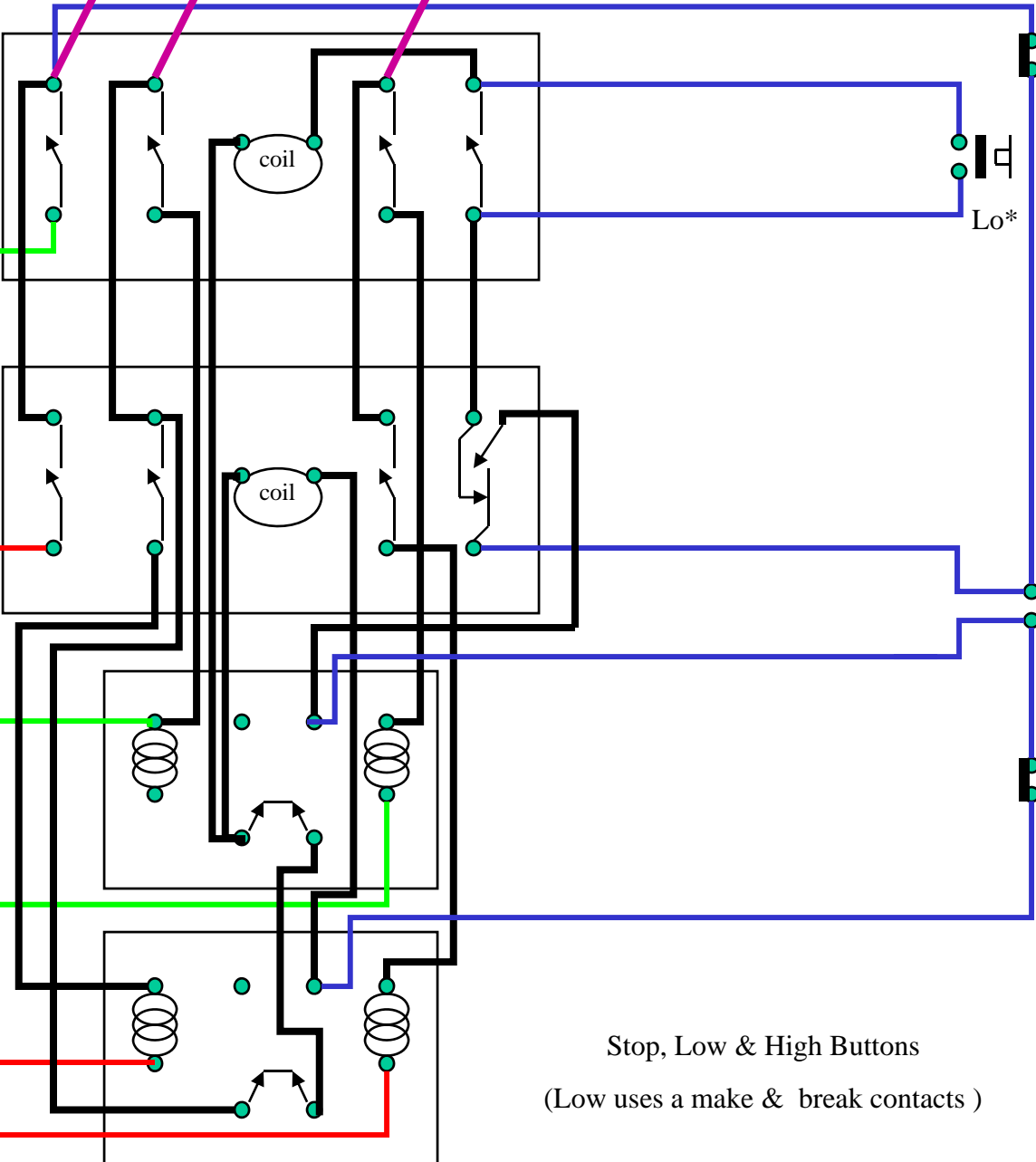

Stop

Lo*

Hi

Lo*

Stop, Low & High Buttons
(Low uses a make & break contacts)

I/C Mains

Table
Motor

Manual switch & overload

2
1
3

Lo

Hi

13
12
11

coil

Lo

coil

Hi

Stop

Lo*

Hi

Lo*

Table Motor Circuit added

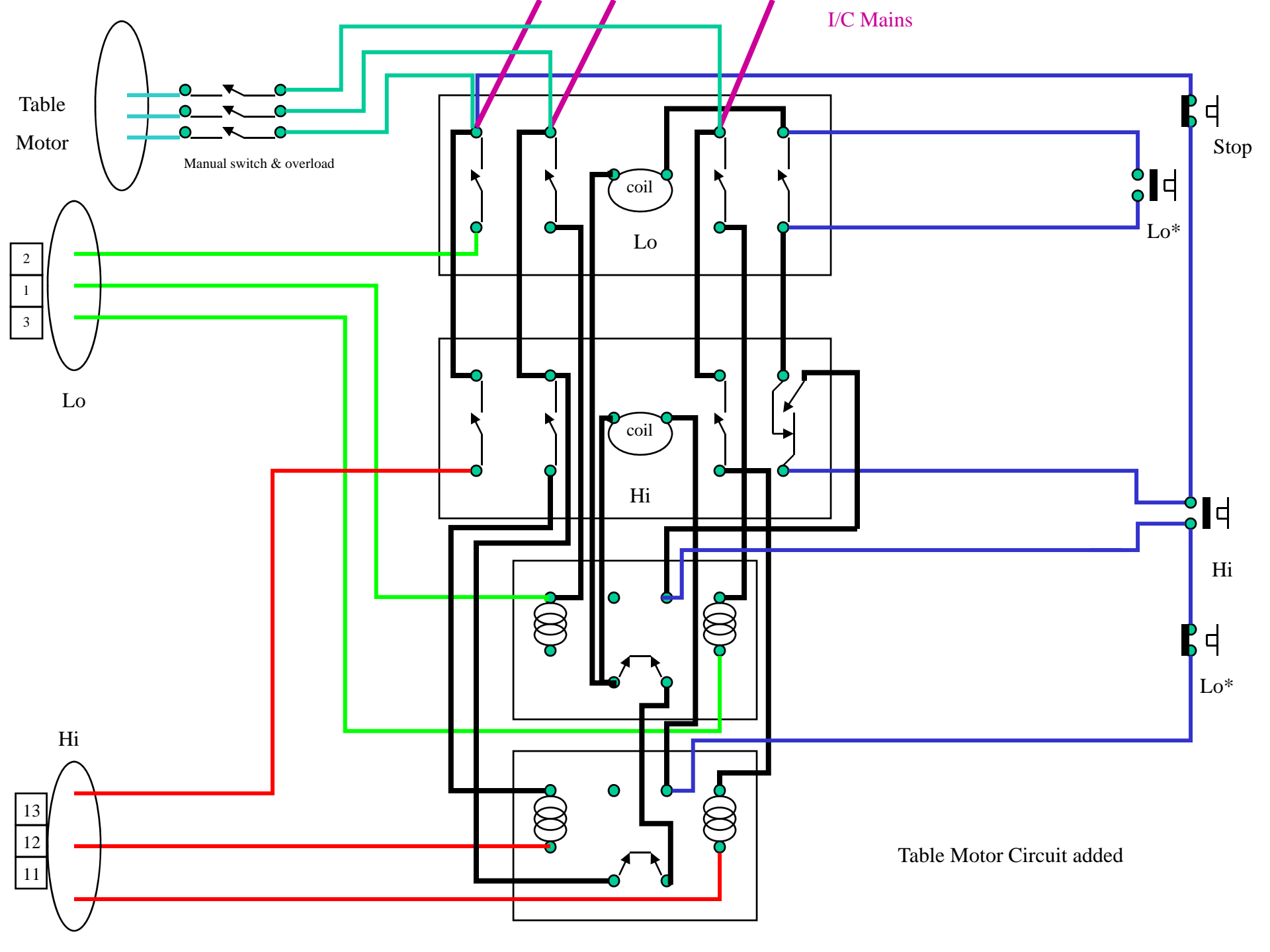

I/C Mains

Table
Motor

Manual switch & overload

Stop

Lo*

Lo

Lo

Hi

Hi

Lo*

Hi

High Speed Running

Power in Red , Control in Blue

(Shown with High Button Pressed)

2
1
3

13
12
11

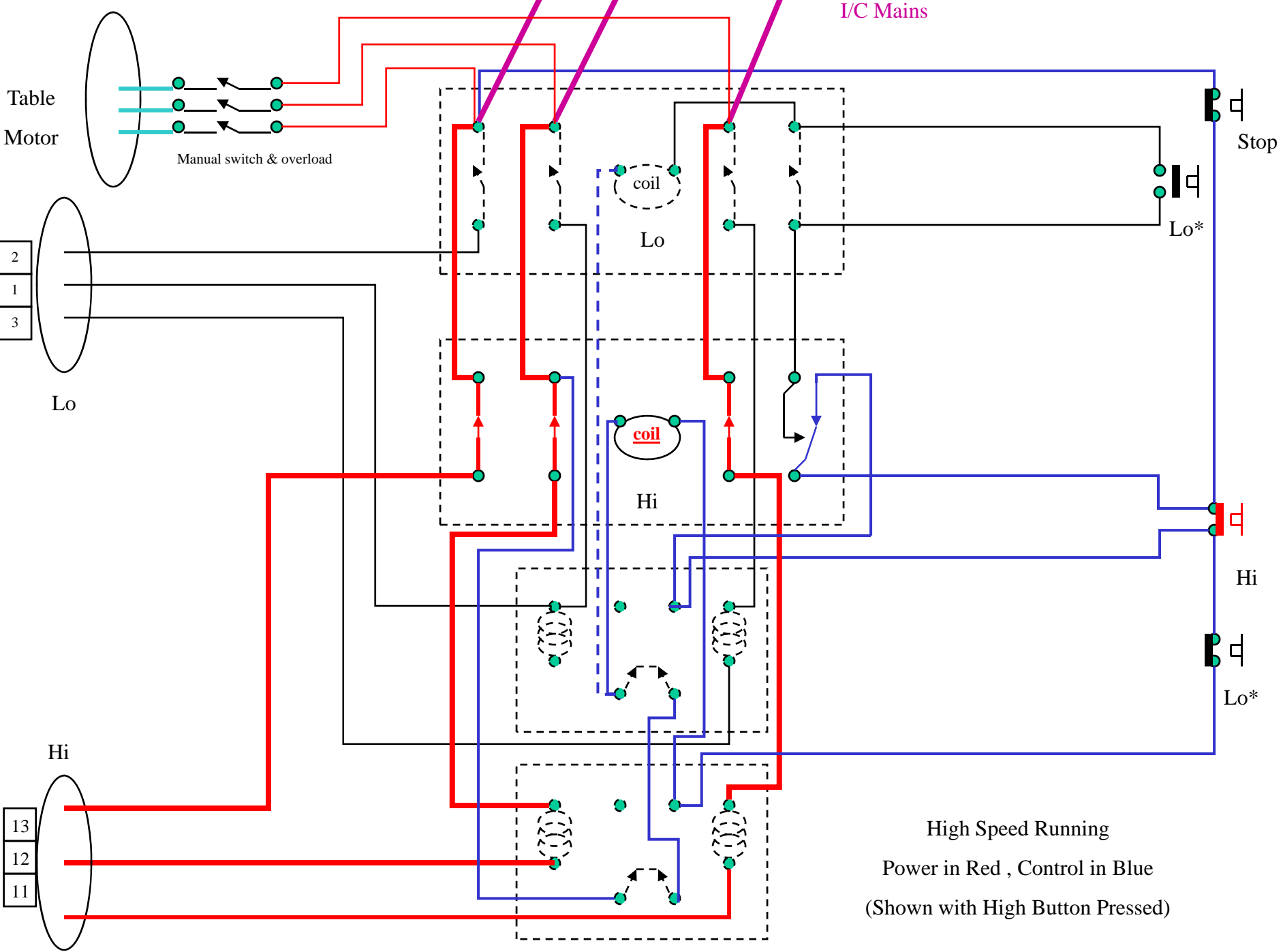

I/C Mains

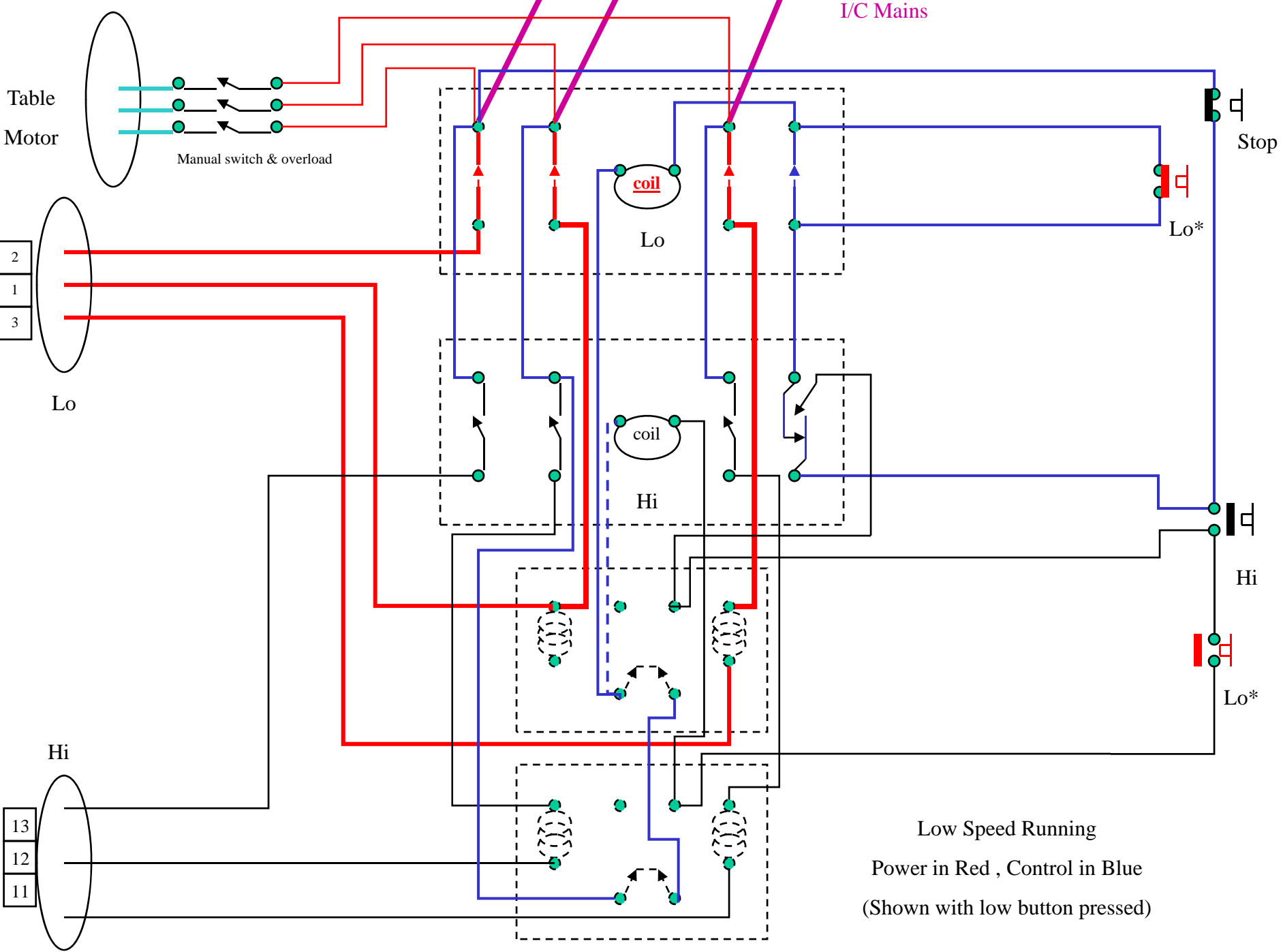

Table
Motor

Manual switch & overload

2
1
3

Lo

Hi

13
12
11

coil

Lo

coil

Hi

Stop

Lo*

Hi

Lo*

Low Speed Running
Power in Red, Control in Blue
(Shown with low button pressed)